

Prime Space Available

Preston and Legacy
Plano, Texas 75025

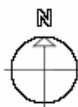

LOT 5 NORTH ELEVATION

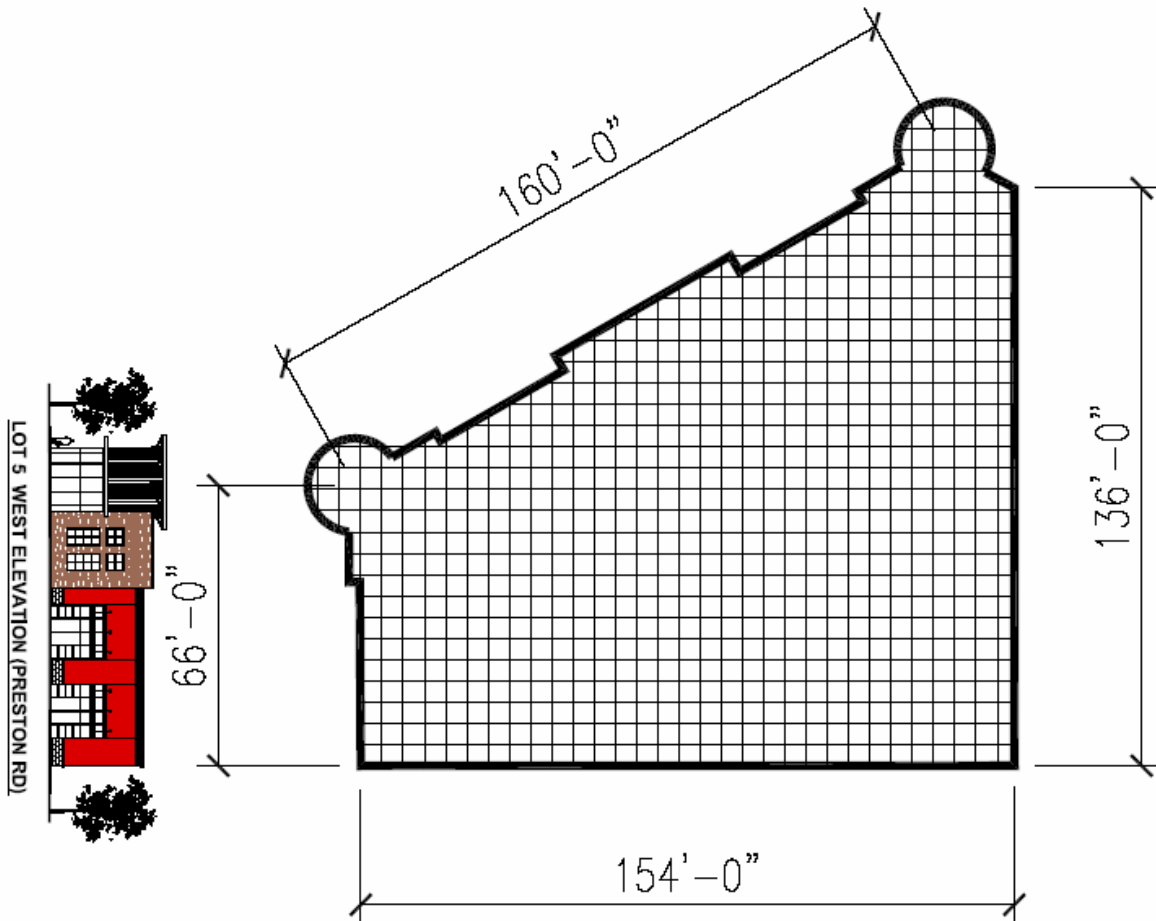

PROPOSED BLDG LOT 5 - 17,000 SQ. FT.

OFFICE, SERVICES OR NON RETAIL

For Lease @ \$30 SF + NNN (\$25 SF TIA)

For Sale @ \$275 SF (Shell Building)

7800 Preston #132
Plano, TX 75024
Phone: 972-618-1047
Fax: 972-421-1715
Email: assist@cwilke.com



Chet Wilke-Broker
Direct: 972-491-2438
VM: 972-733-9560
Fax: 972-690-7064
Email: Chet@Wilke.net

This information is deemed reliable. We make no representations or warranties as to the accuracy of the seller information.